

## **INSTRUCTION SHEET: P/N 302-350**

**IMPORTANT: THIS IS A HIGH PERFORMANCE PART AND IMPROPER INSTALLATION COULD RESULT IN INJURY OR DEATH! NEVER WORK UNDER AN AUTOMOBILE THAT IS NOT PROPERLY SUPPORTED AND BLOCKED FROM ROLLING. ALWAYS INSTALL NEUTRAL SAFETY SWITCH. FAILURE TO DO SO CAN RESULT IN INJURY OR DEATH!**

YOUR WILCAP ADAPTER FLEXPLATE IS SPECIFIC TO YOUR ENGINE BALANCE. EXTERNALLY BALANCED ENGINES MUST HAVE A WEIGHT WELDED TO THE FLEXPLATE. CONTACT WILCAP IF YOU SUSPECT THAT YOU HAVE RECEIVED TO INCORRECT FLEXPLATE.

NO CREDIT OR REFUND WILL BE ISSUED FOR PARTS DAMAGED DUE TO IMPROPER INSTALLATION OR MISAPPLICATION. REMEMBER THAT YOUR ADAPTER PLATE IS ALUMINUM AND NOT CAST IRON. DO NOT OVERTORQUE THE FASTENERS. IF AT ANYTIME YOU HAVE ANY QUESTIONS ABOUT THIS INSTALLATION, CONTACT WILCAP IMMEDIATELY. THE INSTALLATION AND USE OF THIS PRODUCT IS DONE AT YOUR OWN RISK

YOUR WILCAP ADAPTER IS DESIGNED TO USE THE MOPAR SMALL BLOCKGEAR REDUCTION "MINI" STARTER OR ANY EQUIVALENT MOPAR STARTER. THESE STARTERS ARE AVAILABLE FROM WILCAP OR YOUR LOCAL PARTS HOUSE SHOULD BE ABLE TO SUPPLY ONE USING THE FOLLOWING PART NUMBERS;

CHRYSLER P/N 53005984

NIPPONDENSO P/N 128000-781 OR 128000-7810

MOPAR PERFORMANCE P/N/ P5249644

POWERMASTER P/N 9300, 9512, OR 9613

TILTON P/N 54-10000

AUTOLITE PRO P/N 17466

BECK ARNLEY P/N 187-0436

TYPICAL APPLICATION OF THE STARTER WOULD BE A 1992 DODGE DAKOTA WITH THE 5.2L ENGINE.

WILCAP COMPANY  
P.O. Box 763 Pismo Beach, CA 93448  
(805) 481-7639 Fax (805) 343-5000  
[www.wilcap.com](http://www.wilcap.com)

## INSTRUCTION SHEET: P/N 302-350



CHECK THAT ALL OF THE FOLLOWING PARTS ARE IN THE PACKAGE AND FREE OF DAMAGE;

1 ALUMINUM ADAPTER PLATE WITH ONE EACH 3/8" & 7/16" STUDS & NUTS

1 FLEX PLATE

1 ALUMINUM HUB SPACER

FASTENERS; .5- 7/16-14 X 1" UNC SOCKET HEAD CAP SCREWS

1 - 7/16 -14 X1" UNC SOCKET HEAD CAP SCREW TURNED HEAD

6- 3/8 X 2" UNC STUDS & NUTS

6 - 7/16-20 X 1 3/4 UNF GRADE 8 CAP SCREWS AND WASHERS

2 - 7/16-1 1/4 14 HEX HEAD CAP SCREWS FOR STARTER

CLEAN THE CRANKSHAFT FLANGE AND HUB USING SOLVENT AND A RAG AND INSPECT FOR BURRS, DINGS, NICKS, ETC. THIS IS CRITICAL! THE ALIGNMENT OF THE ENTIRE ROTATING ASSEMBLY RELIES ON THE FACE OF THE CRANKSHAFT AND THE HUB SPACER MATING EXACTLY. REMOVE ANY BURRS WITH A FINE PITCH FILE.

CLEAN AND INSPECT THE BLOCK MOUNTING SURFACE AND THE TRANSMISSION MOUNTING SURFACE AND REMOVE ANY BURRS. CHASE AND CLEAN ALL OF THE BLOCK TO BELL HOUSING BOLT HOLES AND REPAIR ANY DAMAGED THREADS. CHECK YOUR DOWEL PINS TO SEE

WILCAP COMPANY  
P.O. Box 763 Pismo Beach, CA 93448  
(805) 481-7639 Fax (805) 343-5000  
[www.wilcap.com](http://www.wilcap.com)

## INSTRUCTION SHEET: P/N 302-350

THAT THEY ARE IN GOOD CONDITION AND NOT “MUSHROOMED”.  
REPLACE IF NEEDED.

CHECK THAT YOUR FLEX PLATE IS THE CORRECT SIZE FOR YOUR TORQUE CONVERTER. EXTERNALLY BALANCED ENGINES ARE TO USE THE MATCH-BALANCED FLEX PLATE WITH THE ADDED BALANCE WEIGHTS. PLEASE CONTACT WILCAP IMMEDIATELY IF YOU HAVE RECEIVED THE INCORRECT FLEX PLATE.



SLIP THE CRANK SHAFT SPACER OVER THE NOSE OF THE TORQUE CONVERTER AND MAKE CERTAIN IT IS A SNUG, SLIDING FIT.

FIT UP THE ADAPTER PLATE TO THE ENGINE BLOCK AND CHECK FOR FIT. THE PLATE SHOULD FIT FLAT TO THE ENGINE BLOCK WITH NO ROCKING OR GAP.

USING THE SUPPLIED 7/16-14 SOCKET HEAD CAP SCREWS, BOLT THE ADAPTER PLATE TO THE BLOCK. THE 7/16-14 SOCKET HEAD CAP SCREW WITH THE TURNED DOWN HEAD IS TO BE USED ON THE LOWER DRIVERS SIDE BOLT HOLE. DO NOT USE THE CAP SCREWS TO FORCE THE PLATE ONTO THE BLOCK. IT SHOULD FLUSH TO THE BLOCK BEFORE YOU BEGIN BOLTING.

ONCE THE ADAPTER PLATE IS FLUSH, MARK THE PLATE FOR ANY TRIMMING OR CUTTING FOR CLEARANCE. IF THE PLATE WILL BE TRIMMED, BE CAREFUL NOT TO CUT TOO CLOSE TO ANY OF THE FASTENER HOLES AND REMOVE ANY BURRS LEFT FROM CUTTING.

WILCAP COMPANY  
P.O. Box 763 Pismo Beach, CA 93448  
(805) 481-7639 Fax (805) 343-5000  
[www.wilcap.com](http://www.wilcap.com)

## INSTRUCTION SHEET: P/N 302-350

AFTER ANY CUTTING OR TRIMMING HAS BEEN COMPLETED, INSTALL THE SOCKET HEAD CAP SCREW WITH THREAD LOCKING COMPOUND AND TORQUE THE BOLTS, CHECK TO MAKE CERTAIN THAT NONE OF THE BOLTS PROTRUDE FROM THE SURFACE OF THE ADAPTER PLATE. IF NEEDED, TRIM THE BOLT HEADS OR SHANKS SO THAT THEY ARE FLUSH OR BELOW THE SURFACE OF THE ADAPTER PLATE.

FOR EXTERNALLY BALANCED ENGINES, THE BALANCE WEIGHTS ARE ON THE ENGINE SIDE OF THE FLEXPLATE.

CAREFULLY ALIGN THE HUB SPACER/FLEX PLATE AND THE CRANKSHAFT BOLT HOLES WHILE PLACING THE HUB SPACER ONTO THE CRANKSHAFT. THE RING GEAR IS OFFSET TOWARDS THE ENGINE. . INSTALL THE CRANKSHAFT BOLTS AND TORQUE TO THE PROPER VALUE.

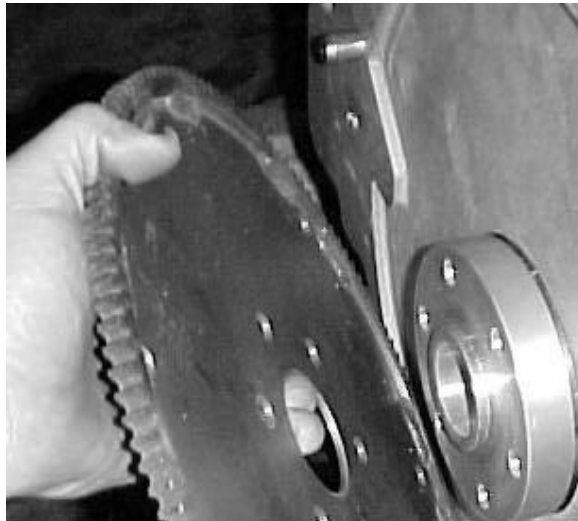

APPLY THREAD LOCKING COMPOUND AND THREAD TO STUDS INTO THE CORRECT HOLES AND USING A STUD DRIVER OR DOUBLE NUTS, INSTALL THE STUDS. WHILE INSTALLING THE TRANSMISSION, REMEMBER THAT THE DOWEL PINS ARE FOR ALIGNMENT ONLY AND WILL NOT BEAR THE WEIGHT OF THE TRANSMISSION.

WILCAP COMPANY  
P.O. Box 763 Pismo Beach, CA 93448  
(805) 481-7639 Fax (805) 343-5000  
[www.wilcap.com](http://www.wilcap.com)

# INSTRUCTION SHEET: P/N 302-350

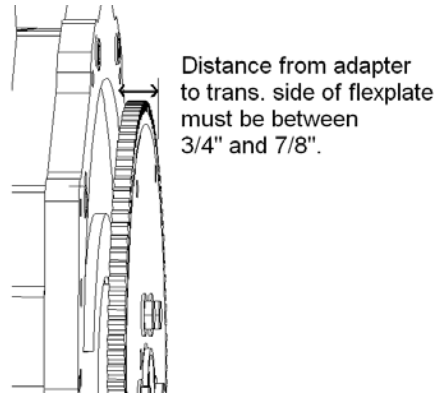

CHECK THE DISTANCE BETWEEN THE TRANSMISSION SIDE OF THE FLEXPLATE AND THE ADAPTER. THIS SHOULD BE BETWEEN .750" AND .875". **DO NOT PROCEED WITH THE INSTALLATION IF THIS IS NOT CORRECT. ASSEMBLING THE MOTOR TO THE TRANSMISSION WITH THIS DIMENSION NOT IN TOLERANCE COULD RESULT IN TRANSMISSION OR STARTER DAMAGE. CONTACT WILCAP IF YOU FIND THIS DIMENSION TO BE GREATER THAN 7/8" OR LESS THAN 3/4".**

FIT UP THE STARTER MOTOR AND CHECK FOR PROPER RING GEAR TO PINION GEAR ENGAGEMENT. THE PINION GEAR OF THE STARTER SHOULD TRAVEL 1/2 TO 2/3 ACROSS THE FACE OF THE RING GEAR WHEN THE SOLENOID IS ACTUATED. PROPER ALIGNMENT OF THE STARTER TO RING GEAR IS OBTAINED WHEN THE REGISTER ON THE FRONT OF THE STARTER IS MATED TO THE OUTSIDE EDGE OF THE STARTER HOLE. TORQUE STARTER BOLTS TO PROPER VALUE.

## WARNING!

Converter flex plate mounting bosses should be 1.0" from the flange when the converter is in fully engaged into the front pump drive.

Make certain this correct before installing the transmission. If the converter is not fully seated into the pump before installing the transmission, the front pump will be damaged!

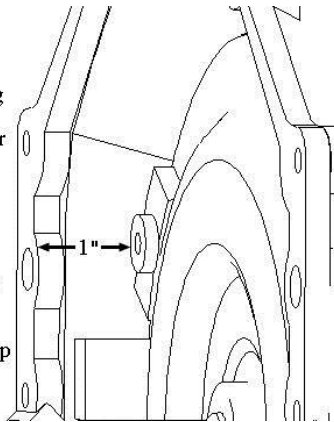

CHECK THAT THE CONVERTER IS SEATED INTO THE FRONT PUMP PRIOR TO INSTALLING THE TRANSMISSION. CHECK THE "PULLBACK" DISTANCE OF THE CONVERTER PRIOR TO INSTALLING THE CONVERTER TO FLEX PLATE BOLTS.

YOUR WILCAP ADAPTER IS DESIGNED TO USE THE STOCK GM DUST COVER. DEPENDING ON THE ORIGINAL APPLICATION, THE DUST COVER MAY NEED TO BE MODIFIED SLIGHTLY. MAKE CERTAIN THAT THE COVER

WILCAP COMPANY

P.O. Box 763 Pismo Beach, CA 93448

(805) 481-7639 Fax (805) 343-5000

[www.wilcap.com](http://www.wilcap.com)

# INSTRUCTION SHEET: P/N 302-350

DOES NOT HIT THE RING GEAR, FLEXPLATE, OR CONVERTER. UNIVERSAL DUST COVERS ARE AVAILABLE FROM WILCAP.

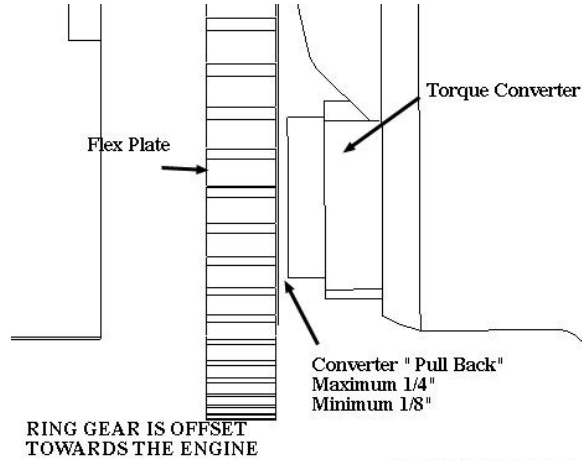

DO NOT HESITATE TO CONTACT US WITH ANY PROBLEMS, IDEAS OR SUGGESTION TO MAKE THIS PRODUCT BETTER. THANKS AGAIN FOR YOUR BUSINESS.

## TORQUE VALUES

ADAPTER PLATE TO ENGINE	7/16-14 SHCS 40-45 FTLBS 7/16-14 HEX HEAD BOLTS 45-50 FTLBS
CRANK SHAFT BOLTS	75-80 FTLBS
BELLOUSING NUTS	30-40 FTLBS

WILCAP COMPANY  
P.O. Box 763 Pismo Beach, CA 93448  
(805) 481-7639 Fax (805) 343-5000  
[www.wilcap.com](http://www.wilcap.com)