

312-350 INSTRUCTIONS

ENGINE APPLICATION YEARS/CID:	FORD/MERCURY V8 256, 292, 312 1954-1964
TRANS APPLICATION YEAR/MODEL:	GM AUTO PG, TH350, 400, 700R4, CHEVY OR GM UNICASE
STARTER USED:	MODIFIED MOPAR 2 BOLT GEAR REDUCTION DRIVE "MINI" STARTER

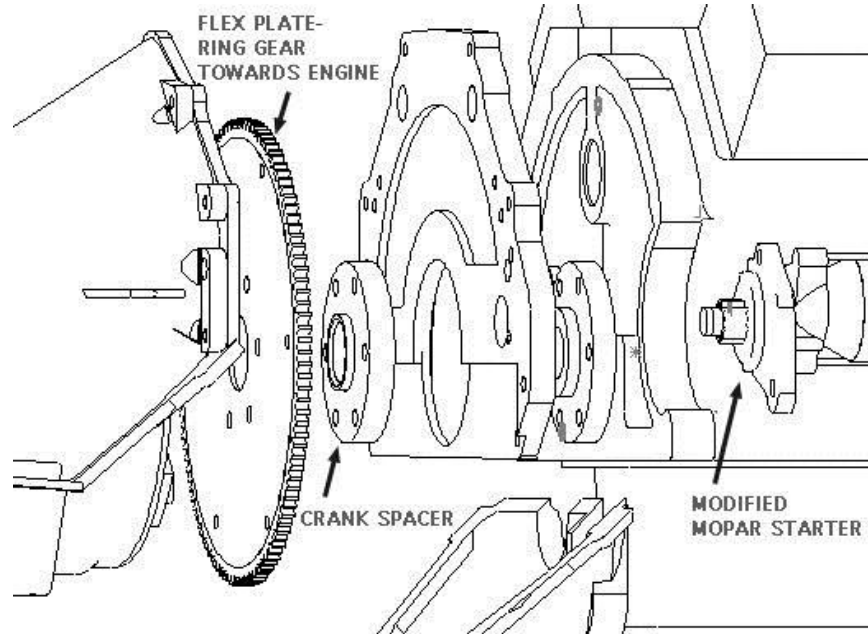

IMPORTANT: THIS IS A HIGH PERFORMANCE PART AND IMPROPER INSTALLATION COULD RESULT IN INJURY OR DEATH! NEVER WORK UNDER AN AUTOMOBILE THAT IS NOT PROPERLY SUPPORTED AND BLOCKED FROM ROLLING. NO CREDIT OR REFUND WILL BE ISSUED FOR PARTS DAMAGED DUE TO IMPROPER INSTALLATION. REMEMBER THAT YOUR ADAPTER PLATE IS ALUMINUM AND NOT CAST IRON. DO NOT OVERTORQUE THE FASTENERS. IF AT ANYTIME YOU HAVE ANY QUESTIONS ABOUT THIS INSTALLATION, CONTACT WILCAP OR YOUR WILCAP DEALER IMMEDIATELY. THE INSTALLATION AND USE OF THIS PRODUCT IS DONE AT YOUR OWN RISK!

YOUR ADAPTER IS SUPPLIED WITH A NEUTRAL BALANCE FLEXPLATE. IF YOUR ENGINE IS EXTERNALLY BALANCED, THE FLEXPLATE MUST BE MATCH-BALANCED TO YOUR ENGINE.

**YOUR WILCAP ADAPTER IS DESIGNED TO USE A MODIFIED MOPAR SMALL BLOCKGEAR REDUCTION "MINI" STARTER. THESE STARTERS ARE AVAILABLE FROM WILCAP OR YOUR LOCAL PARTS HOUSE SHOULD BE ABLE TO SUPPLY ONE USING THE FOLLOWING PART NUMBERS;
CHRYSLER P/N 53005984
NIPPONDENSO P/N 128000-781 OR 128000-7810**

Wilcap Company
P.O. Box 763
Pismo Beach, CA 93448
(805) 481-7639
www.wilcap.com
Copyright 2002 All Rights Reserved.

312-350 INSTRUCTIONS

MOPAR PERFORMANCE P/N/ P5249644
POWERMASTER P/N 9300, 9512, OR 9613
TILTON P/N 54-10000
AUTOLITE PRO P/N 17466
BECK ARNLEY P/N 187-0436
TYPICAL APPLICATION OF THE STARTER WOULD BE A 1992 DODGE
DAKOTA WITH THE 5.2L ENGINE.

CHECK THAT ALL OF THE FOLLOWING PARTS ARE IN THE PACKAGE AND
FREE OF DAMAGE;

1 CAST ALUMINUM ADAPTER PLATE

1 FLEX PLATE

1 ALUMINUM HUB SPACER

2- SPECIAL OFFSET BOLTS WITH NUTS & WASHERS

4- DOUBLE ENDED 3/8 STUDS WITH NUTS AND LOCK WASHERS

2- 7/16 -14 X 1 1/4" UNC HEX HEAD BOLTS

6 - 7/16- 20 x 1 1/2" BOLTS AND WASHERS

2 7/16-14 X 1 1/4" BOLTS AND WASHERS FOR STARTER

ADAPTER PLATE TO ENGINE	7/16-14 HEX HEAD BOLTS 45-50 FTLBS
CRANK SHAFT BOLTS	75-80 FTLBS
BELLOUSING NUTS	30-40 FTLBS



CLEAN THE CRANKSHAFT FLANGE AND HUB USING SOLVENT AND A RAG
AND INSPECT FOR BURRS, DINGS, NICKS, ETC. THIS IS CRITICAL! THE
ALIGNMENT OF THE ENTIRE ROTATING ASSEMBLY RELIES ON THE FACE
OF THE CRANKSHAFT AND THE HUB SPACER MATING EXACTLY. REMOVE
ANY BURRS WITH A FINE PITCH FILE.

312-350 INSTRUCTIONS

CLEAN AND INSPECT THE BLOCK MOUNTING SURFACE AND THE TRANSMISSION MOUNTING SURFACE AND REMOVE ANY BURRS. CHASE AND CLEAN ALL OF THE BLOCK TO BELL HOUSING BOLT HOLES AND REPAIR ANY DAMAGED THREADS.



BECAUSE OF CLEARANCE, FOR YOUR APPLICATION YOU MUST MODIFY THE STARTER. THE "NOSE" OF THE STARTER MUST BE REMOVED. THIS REQUIRES THE USE OF A LATHE, BANDSAW, OR HACK SAW. MOST ANY MACHINE SHOP CAN PERFORM THIS OPERATION SAFELY AT A REASONABLE COST. WILCAP ALSO HAS THE MODIFIED STARTER AVAILABLE.

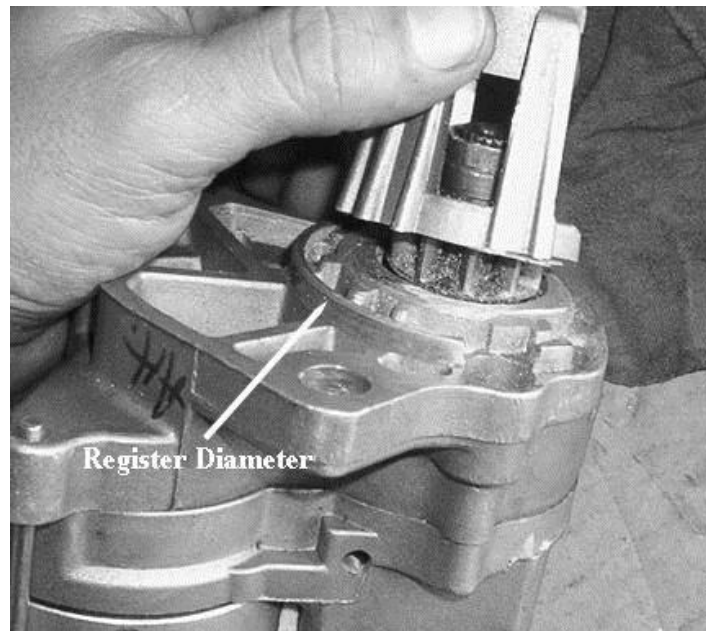

312-350 INSTRUCTIONS

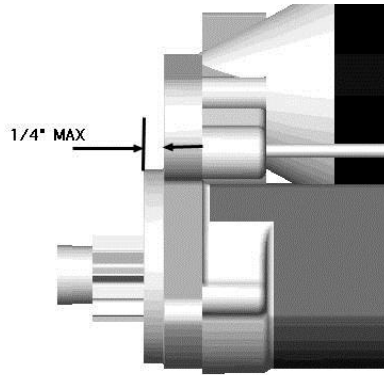

THE BELLHOUSING WILL NEED TO BE MODIFIED TO ALLOW FOR CLEARANCE FOR THE MOPAR TYPE STARTER. THIS REQUIRES THE USE OF POWER TOOLS AND MEASURING INSTRUMENTS. IF YOU ARE NOT QUALIFIED TO PERFORM THIS MODIFICATION, SEEK ASSISTANCE FROM A LOCAL MACHINE SHOP. ALSO, BE AWARE THAT MODIFYING YOUR TRANSMISSION CASE MAY VOID ANY WARRANTY OR CERTIFICATIONS. THE MOPAR TYPE STARTER MUST ALSO BE MODIFIED.

PLACE THE ADAPTER PLATE ONTO THE TRANSMISSION BELLHOUSING AND MARK THE AREA SHOWING THROUGH THE STARTER HOLE IN THE ADAPTER PLATE.

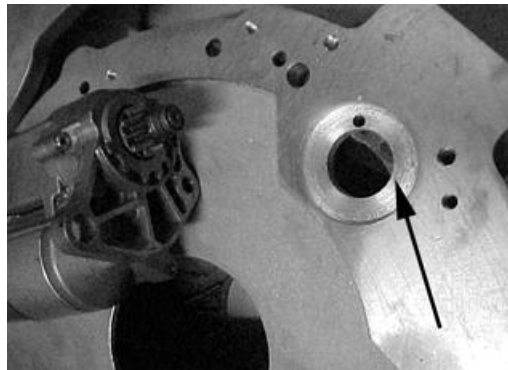

REMOVE THE ADAPTER PLATE AND MARK STRAIGHT OUT TO THE EDGE OF THE BELLHOUSING FROM THE EDGES OF THE CIRCLE.

MEASURE AND MARK 1 INCH (1") DOWN FROM THE SURFACE AND MARK A LINE PARALLEL TO THE SURFACE.

312-350 INSTRUCTIONS



JOIN THE THREE LINES. THIS IS THE AREA THE MUST BE CUT FOR CLEARANCE.

THE PREFERED METHOD IS TO MILL OUT THIS AREA USING A 1 5/8" END MILL. BY BOLTING THE ADAPTER PLATE TO THE BELLHOUSING, THE CENTER OF THE 1 5/8" DIAMETER CAN BE FOUND. ALTERNATIVLEY, TWO SMALL DIAMETER HOLES CAN BE DRILLED AT THE INTERSECTION OF THE MARKS AND THE ENTIRE AREA CAN BE CUT AWAY USING A SAW OR A DIE GRINDER.

ONCE THE MATERIAL HAS BEEN REMOVED, INSTALL THE STARTER ONTO THE ADAPTER PLATE USING THE PROVIED SOCKET HEAD CAP SCREW AND NUT AND THE HEX HEAD BOLT AND THE ADAPTER PLATE ONTO THE BELLHOUSING. PULL THE STARTER PINION SHAFT OUT TO ITS FULL TRAVEL LENGTH AND CHECK THAT THERE IS SUFFECIENT CLEARANCE

PLACE THE ADAPTER PLATE ONTO THE ENGINE BLOCK. IF NECESSARY USE A RUBBER Mallet TO FIT THE PLATE UP TO THE BLOCK FLUSH. DO NOT USE THE CAP SCREWS TO FORCE THE PLATE ONTO THE BLOCK. IF THE PLATE WILL NOT SIT FLUSH TO THE BLOCK, CHECK THE DOWEL PINS ON THE BLOCK TO SEE IF THEY HAVE BEEN DAMAGED. IF THE TRANSMISSION IS INSTALLED WITH THE DOWELS MISSING THE ALIGNMENT OF THE ENGINE TO TRANSMISSION WILL NOT BE CORRECT AND THE TRANSMISSION WILL FAIL IN SHORT ORDER.

INSTALL THE BOTTOM 2 CAP SCREWS AND THE OFFSET BOLTS WITH THREAD LOCKING COMPOUND AND TORQUE IN A CRISS-CROSS PATTERN TO THE PROPER VALUES. AFTER TORQUING THE BOLTS, CHECK TO MAKE CERTAIN THAT THE OFFSET BOLTS DO NOT PROTRUDE FROM THE

312-350 INSTRUCTIONS

SURFACE OF THE ADAPTER PLATE. IF NEEDED TRIM THE SHANKS SO THAT THEY ARE FLUSH OR BELOW THE SURFACE OF THE ADAPTER PLATE.

INSTALL THE 2 SPECIAL OFFSET FASTENERS. SCREW THEM FLUSH WITH THE BLOCK USING THE 1/4" ALLEN SCREW.

ROTATE THE OFFSET FASTENERS TO LINE UP THE MARKS ON THE PLATE WITH THOSE ON THE FASTENERS.

THE RING GEAR IS OFFSET TO THE ENGINE SIDE OF THE FLEX PLATE. FROM THIS SIDE, FIT THE HUB SPACER INTO THE FLEX PLATE AND ALIGN THE CRANKSHAFT BOLT HOLES. THIS SHOULD BE A SNUG FIT. IMPORTANT! ANY TIME THAT ANY FORCE IS APPLIED TO THE HUB SPACER USE ONLY A RUBBER Mallet OR WOODEN DOWEL.

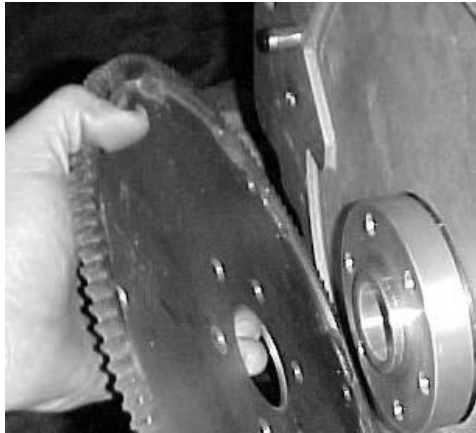

CAREFULLY ALIGN THE HUB SPACER/FLEX PLATE AND THE CRANKSHAFT BOLT HOLES WHILE PLACING THE HUB SPACER ONTO THE CRANKSHAFT. THE HUB SPACER SHOULD BE A CLOSE FIT TO THE CRANKSHAFT. INSTALL THE CRANKSHAFT BOLTS WITH THREAD LOCKING COMPOUND AND TORQUE TO THE PROPER VALUE.

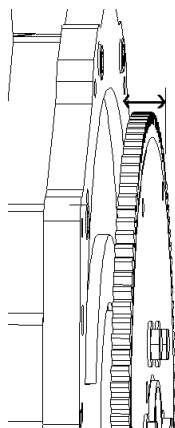

Distance from adapter to trans. side of flexplate must be between 3/4" and 7/8".

312-350 INSTRUCTIONS

CHECK THE DISTANCE BETWEEN THE TRANSMISSION SIDE OF THE FLEXPLATE AND THE ADAPTER. THIS SHOULD BE BETWEEN .750" AND .875". **DO NOT PROCEED WITH THE INSTALLATION IF THIS IS NOT CORRECT.** ASSEMBLING THE MOTOR TO THE TRANSMISSION WITH THIS DIMENSION NOT IN TOLERANCE COULD RESULT IN TRANSMISSION OR STARTER DAMAGE. CONTACT WILCAP IF YOU FIND THIS DIMENSION TO BE GREATER THAN 7/8" OR LESS THAN 3/4".

FIT UP THE STARTER MOTOR AND CHECK FOR PROPER RING GEAR TO PINION GEAR ENGAGEMENT. ADJUST IF NEEDED AND TORQUE STARTER BOLTS TO PROPER VALUE



BEFORE INSTALLING THE TRANSMISSION, CHECK THAT THE TORQUE CONVERTER IS FULLY SEATED INTO THE FRONT PUMP OF THE TRANSMISSION. THE TORQUE CONVERTER MATING BOSSES SHOULD BE APPROXIMATELY 1" FROM THE BELLHOUSING FACE.

WARNING!
Converter flex plate mounting bosses should be 1.0" from the flange when the converter is in fully engaged into the front pump drive.
Make certain this correct before installing the transmission. If the converter is not fully seated into the pump before installing the transmission, the front pump will be damaged!

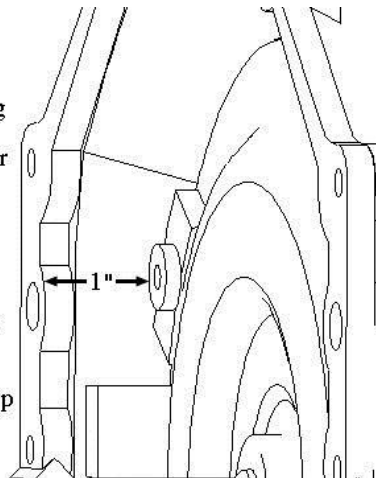

312-350 INSTRUCTIONS

WHILE INSTALLING THE TRANSMISSION, REMEMBER THAT THE DOWEL PINS ARE FOR ALIGNMENT ONLY AND WILL NOT BEAR THE WEIGHT OF THE TRANSMISSION. IF THE ENTIRE WEIGHT OF THE TRANSMISSION IS PUT ONTO THE DOWELS THEY WILL BE PULLED FROM THE ADAPTER PLATE.

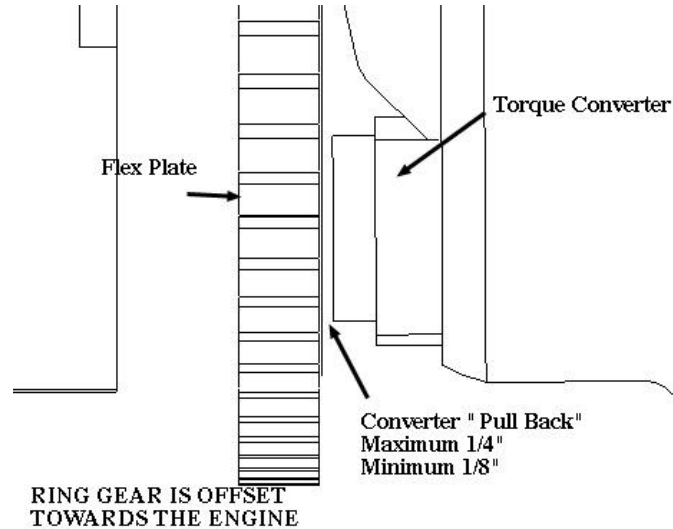

COPYRIGHT WILCAP COMPANY 2005

CHECK THE “PULLBACK” DISTANCE OF THE CONVERTER PRIOR TO INSTALLING THE CONVERTER TO FLEX PLATE BOLTS. YOUR WILCAP ADAPTER IS DESIGNED TO USE THE STOCK GM DUST COVER. DEPENDING ON THE ORIGINAL APPLICATION, THE DUST COVER MAY NEED TO BE MODIFIED SLIGHTLY. MAKE CERTAIN THAT THE COVER DOES NOT HIT THE RING GEAR, FLEXPLATE, OR CONVERTER. UNIVERSAL DUST COVERS ARE AVAILABLE FROM WILCAP.

ALIGN THE CONVERTER AND THE FLEXPLATE HOLES AND START EACH BOLT. ROTATE THE ENGINE AS YOU TORQUE THE CONVERTER BOLTS TO THEIR FINAL VALUE IN AT LEAST THREE STEPS.

YOUR BELL HOUSING TO ADAPTER PLATE BOLTS SHOULD GO INTO THE ADAPTER PLATE A MINIMUM OF 1/2”. YOUR BELL HOUSING BOLTS SHOULD ALLOW FOR 1/2” OF THREAD INTO THE ADAPTER PLATE. ALSO CHECK THAT THE BOLTS DO NOT REACH PAST THE ADAPTER PLATE AND HIT THE BLOCK. USE THREAD LOCKING COMPOUND ON THE ADAPTER TO BELL HOUSING BOLTS.