

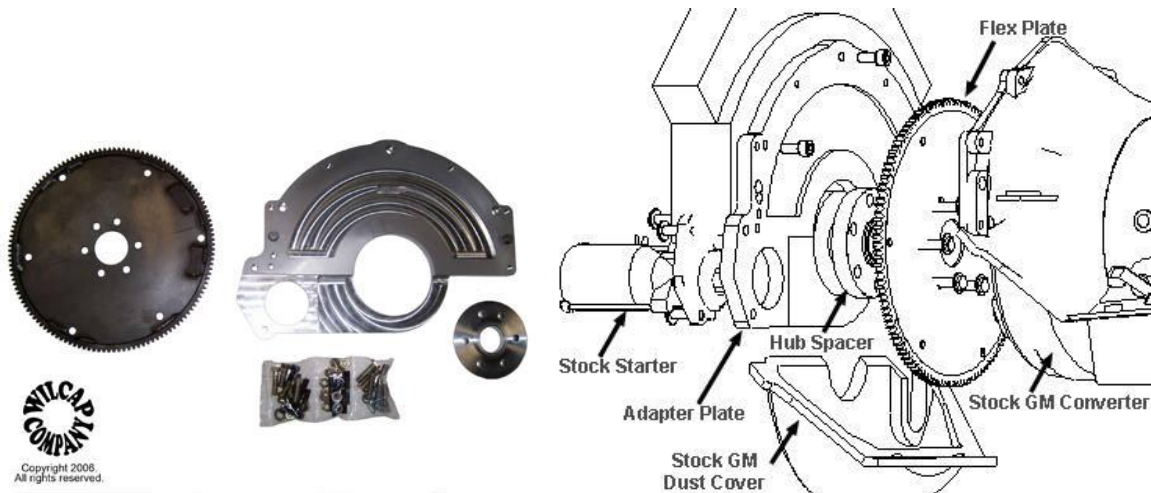

# 318-350 SB Mopar to Chevy ENGINE TO TRANSMISSION ADAPTER

ENGINE APPLICATION YEARS/CID:	MOPAR SMALL BLOCK 62-91 273,318,340,360 CI V8
TRANS APPLICATION YEAR/MODEL:	CHEVY V8 90 DEG. V6 AUTO P.G. TH-350, TH-400, 200-4R, 700R4
STARTER USED:	1966-1999 MOPAR 2 BOLT STARTER, GEAR REDUCTION OR DIRECT DRIVE
FLYWHEEL USED:	INCLUDED. NOTE CUSTOMER MUST SUPPLY ENGINE BALANCE INFO.
CLUTCH USED:	NA
MATERIAL / MACHINING METHODS:	WILCAP CNC MACHINED 6061 T6 ALUMINUM ADAPTER PLATE, DOWEL PINS, ALLOY ENGINE TO ADAPTER FASTENERS.
ADDITIONAL PARTS NEEDED:	ENGINE, TRANSMISSION. STARTER



NOTES; Complete instructions are included. We do not supply information regarding engine or transmission installation in to specific frames, bodies, etc. This is the responsibility of the customer and care should be taken to address the issues of motor and transmission mounts, driveline, body and frame clearance, gear ratios, etc. BEFORE the purchase of the engine to transmission adapter. We can assist you with information and dimensions prior to the start of your project so feel free to contact us with any questions.

**WILCAP COMPANY**  
**P.O. BOX 763, PISMO BEACH, CA 93448**  
**(805) 481-7639 FAX (805) 481-9367**  
[www.wilcap.com](http://www.wilcap.com)  
 Copyright 2008 All rights reserved.