

WILCAP

392-302 ENGINE TO TRANSMISSION ADAPTER

ENGINE APPLICATION YEARS/CID:	V8 CHRYSLER 54-58, DODGE 53-58, DESOTO 52-58, PLYMOUTH 55-58
TRANS APPLICATION YEAR/MODEL:	FORD 1965-PRESENT 289, 302, 351 MANUAL TRANSMISSION W/ BELLHOUSING
STARTER USED:	1966-1999 MOPAR 2 BOLT STARTER, GEAR REDUCTION.
MATERIAL / MACHINING METHODS:	WILCAP CNC MACHINED CAST ALUMINUM ADAPTER PLATE, STEEL OR ALUMINUM FLYWHEEL, DOWEL PINS, GRADE 8 CRANKSHAFT ATACHMENT BOLTS, ALLOY ENGINE TO ADAPTER FASTENERS.
ADDITIONAL PARTS NEEDED:	ENGINE, TRANSMISSION, BELLHOUSING STARTER, TRANSMISSION BELLHOUSING TO ADAPTER PLATE BOLTS, OIL FILTER ADAPTER (IF NEEDED)

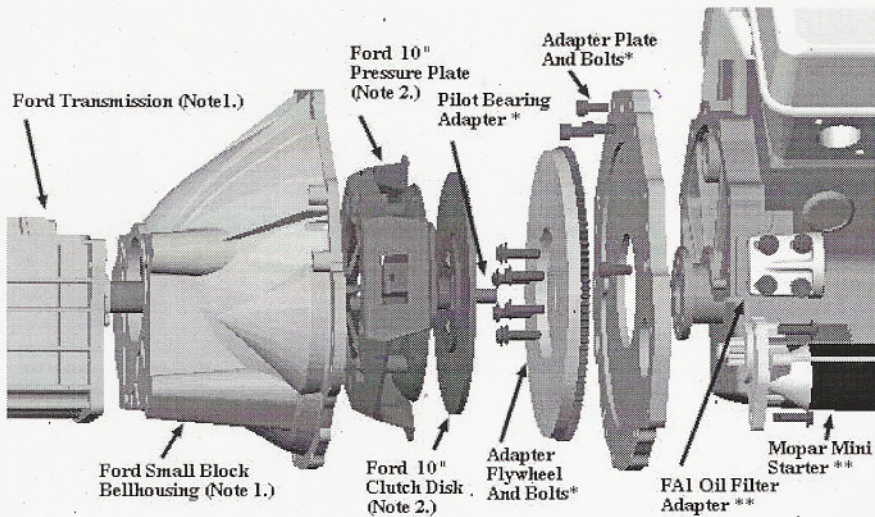

NOTE 1. USE THE FORD SMALL BLOCK BELLHOUSING, THROWOUT BEARING AND LINKAGE (FORK) THAT WERE STOCK TO YOUR TRANSMISSION

NOTE 2. USE FORD 10" DISK AND PRESSURE PLATE FROM THE TRANSMISSIONS' ORIGINAL APPLICATION. TRANSMISSION; T5 1979-1985; APPLICATION; 5.0 V8 MUSTANG, MERCURY CAPRI, COUGAR, FAIRMONT, ZEPHYR TRANSMISSION; 1965-1978 3 & 4 SPEEDS; 4.7 & 5.0 V8 MUSTANG, FAIRLANE, FALCON, GALAXIE, MAVERICK, RANCHERO, E&F SERIES VANS & TRUCKS.

DISK AND PRESSURE PLATE ARE AVAILABLE FROM WILCAP.

* INCLUDED IN KIT

** AVAILABLE FROM WILCAP.

NOTES; The 392-302 allows you to use any manual transmission with its bellhousing that was originally behind the Ford small block. By request, we can drill the flywheel for 1/2" bolts. Because of the location of the starter, it may be necessary to use an oil filter adapter such as our FA1. The adapter plate has ears that protrude from the sides for use in mounting the engine or they may be trimmed off if they get in the way of your particular application. Unlike our competition NO modification of the starter nor drilling of the bell housing or engine is necessary. We can supply starter. Complete instructions are included for installing the adapter. We do not supply information regarding engine or transmission installation in to specific frames, bodies, etc. This is the responsibility of the customer and care should be taken to address the issues of motor and transmission mounts, driveline, body and frame clearance, gear ratios, etc. BEFORE the purchase of the engine to transmission adapter. We can assist you with information and dimensions prior to the start of your project so feel free to contact us with any questions.

WILCAP COMPANY

P.O. BOX 763, PISMO BEACH, CA 93448

(805) 481-7639 FAX 343-5000

www.wilcap.com

Copyright 2003 All rights reserved.