

426-350 INSTALLATION INSTRUCTIONS

ENGINE APPLICATION YEARS/CID	V8 CHRYSLER BIG BLOCK 361,383,400, 413,426,440 6 OR 8 BOLT CRANKSHAFT
TRANS APPLICATION YEAR/MODEL	CHEVY AUTO; PG, TH350, 400, 700R4, 4L60, 4L80

IMPORTANT: THIS IS A HIGH PERFORMANCE PART AND IMPROPER INSTALLATION COULD RESULT IN INJURY OR DEATH! NEVER WORK UNDER AN AUTOMOBILE THAT IS NOT PROPERLY SUPPORTED AND BLOCKED FROM ROLLING. ALWAYS INSTALL NEUTRAL SAFETY SWITCH. FAILURE TO DO SO CAN RESULT IN INJURY OR DEATH! IF AT ANYTIME YOU HAVE ANY QUESTIONS ABOUT THIS INSTALLATION, CONTACT WILCAP OR YOUR WILCAP DEALER IMMEDIATELY. THE INSTALLATION AND USE OF THIS PRODUCT IS DONE AT YOUR OWN RISK! YOUR ADAPTER IS SUPPLIED WITH A NEUTRAL BALANCE FLEXPLATE. IF YOUR ENGINE IS EXTERNALLY BALANCED, THE FLEXPLATE MUST BE MATCH-BALANCED TO YOUR ENGINE.

YOUR WILCAP ADAPTER IS DESIGNED TO USE A MODIFIED MOPAR SMALL BLOCKGEAR REDUCTION "MINI" STARTER. THESE STARTERS ARE AVAILABLE FROM WILCAP OR YOUR LOCAL PARTS HOUSE SHOULD BE ABLE TO SUPPLY ONE USING THE FOLLOWING PART NUMBERS;

CHRYSLER P/N 53005984

NIPPONDENSO P/N 128000-781 OR 128000-7810

MOPAR PERFORMANCE P/N/ P5249644

POWERMASTER P/N 9300, 9512, OR 9613

TILTON P/N 54-10000

AUTOLITE PRO P/N 17466

BECK ARNLEY P/N 187-0436

TYPICAL APPLICATION OF THE STARTER WOULD BE A 1992 DODGE DAKOTA WITH THE 5.2L ENGINE.

CHECK THAT ALL OF THE FOLLOWING PARTS ARE IN THE PACKAGE AND FREE OF DAMAGE;

1 CAST ALUMINUM ADAPTER PLATE

1 FLEX PLATE

1 ALUMINUM HUB SPACER 6 OR 8 HOLE MATCHED TO YOUR CRANKSHAFT FASTENERS;

6 3/8 STUDS, NUTS AND LOCK WASHERS

2 7/16 – 14 X 1 1/4 STARTER BOLTS

1- 7/16 – 14 X 1 1/2" UNC CAP SCREWS

1 - 7/16 – 14 X 1 3/4" UNC CAP SCREW

4 – 3/8 – 16 X 1" UNC SOCKET HEAD CAP SCREWS

6 7/16- 20 x 1 1/2"

or 8 1/2-20 x 1 1/2" CRANKSHAFT BOLTS AND LOCK WASHERS

TORQUE VALUES

WILCAP COMPANY
P.O. Box 763 Pismo Beach, CA 93448
(805) 481-7639 Fax (805) 343-5000
www.wilcap.com

426-350 INSTALLATION INSTRUCTIONS

ADAPTER PLATE TO ENGINE	3/8-16 SHCS 35-40 FTLBS 7/16-14 HEX HEAD BOLTS 45-50 FTLBS
CRANK SHAFT BOLTS	75-80 FTLBS
BELLOUSING NUTS	30-40 FTLBS

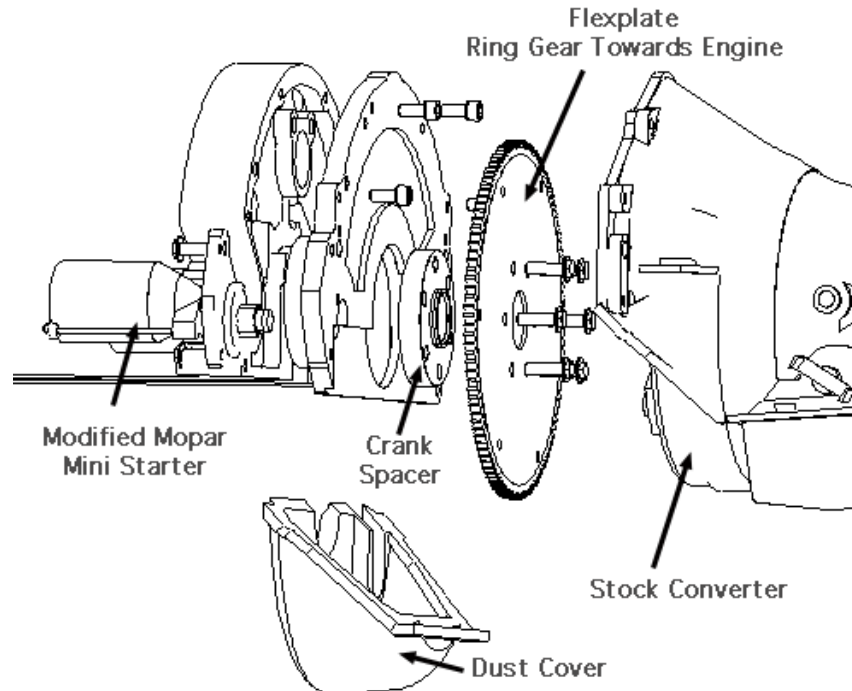

CLEAN THE CRANKSHAFT FLANGE AND HUB USING SOLVENT AND A RAG AND INSPECT FOR BURRS, DINGS, NICKS, ETC. THIS IS CRITICAL! THE ALIGNMENT OF THE ENTIRE ROTATING ASSEMBLY RELIES ON THE FACE OF THE CRANKSHAFT AND THE HUB SPACER MATING EXACTLY. REMOVE ANY BURRS WITH A FINE PITCH FILE.

CLEAN AND INSPECT THE BLOCK MOUNTING SURFACE AND THE TRANSMISSION MOUNTING SURFACE AND REMOVE ANY BURRS. CHASE AND CLEAN ALL OF THE BLOCK TO BELL HOUSING BOLT HOLES AND REPAIR ANY DAMAGED THREADS.

426-350 INSTALLATION INSTRUCTIONS

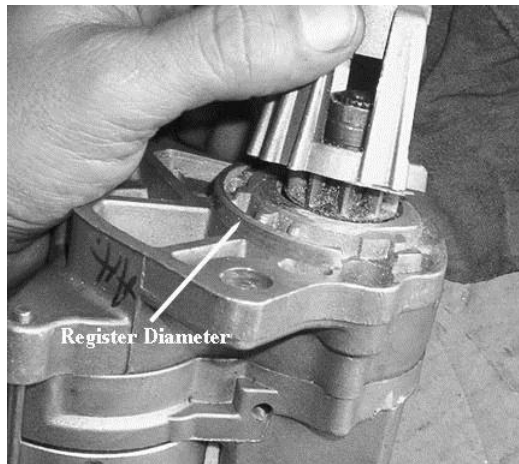

BECAUSE OF CLEARANCE, FOR YOUR APPLICATION YOU MUST MODIFY THE STARTER. THE "NOSE" OF THE STARTER MUST BE REMOVED. THIS REQUIRES THE USE OF A LATHE, BANDSAW, OR HACK SAW. MOST ANY MACHINE SHOP CAN PERFORM THIS OPERATION SAFELY AT A REASONABLE COST. WILCAP ALSO HAS THE MODIFIED STARTER AVAILABLE.

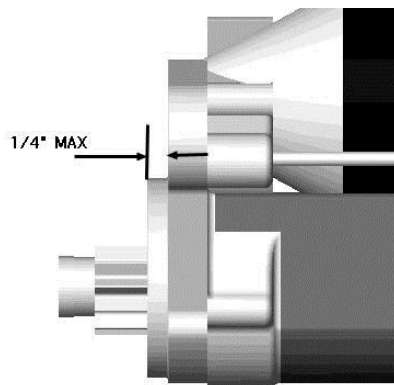

THE BELLHOUSING WILL NEED TO BE MODIFIED TO ALLOW FOR CLEARANCE FOR THE MOPAR TYPE STARTER. THIS REQUIRES THE USE OF

WILCAP COMPANY
P.O. Box 763 Pismo Beach, CA 93448
(805) 481-7639 Fax (805) 343-5000
www.wilcap.com

426-350 INSTALLATION INSTRUCTIONS

POWER TOOLS AND MEASURING INSTRUMENTS. IF YOU ARE NOT QUALIFIED TO PERFORM THIS MODIFICATION, SEEK ASSISTANCE FROM A LOCAL MACHINE SHOP. ALSO, BE AWARE THAT MODIFYING YOUR TRANSMISSION CASE MAY VOID ANY WARRANTY OR CERTIFICATIONS.

PLACE THE ADAPTER PLATE ONTO THE TRANSMISSION BELLHOUSING AND MARK THE AREA SHOWING THROUGH THE STARTER HOLE IN THE ADAPTER PLATE.

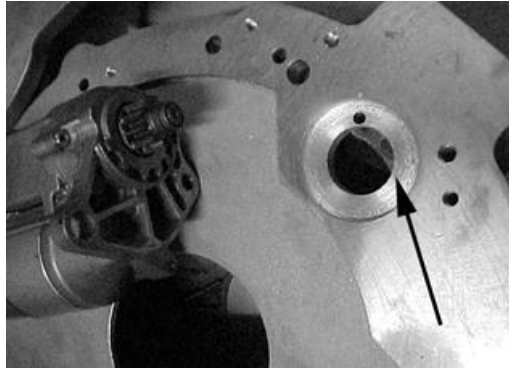

REMOVE THE ADAPTER PLATE AND MARK STRAIGHT OUT TO THE EDGE OF THE BELLHOUSING FROM THE EDGES OF THE CIRCLE.

MEASURE AND MARK 1 INCH (1") DOWN FROM THE SURFACE AND MARK A LINE PARALLEL TO THE SURFACE.



JOIN THE THREE LINES. THIS IS THE AREA THAT MUST BE CUT FOR CLEARANCE.

THE PREFERRED METHOD IS TO MILL OUT THIS AREA USING A 1 5/8" END MILL. BY BOLTING THE ADAPTER PLATE TO THE BELLHOUSING, THE CENTER OF THE 1 5/8" DIAMETER CAN BE FOUND. ALTERNATIVELY, TWO SMALL DIAMETER HOLES CAN BE DRILLED AT THE INTERSECTION OF THE MARKS AND THE ENTIRE AREA CAN BE CUT AWAY USING A SAW OR A DIE GRINDER.

426-350 INSTALLATION INSTRUCTIONS

ONCE THE MATERIAL HAS BEEN REMOVED, INSTALL THE STARTER ONTO THE ADAPTER PLATE AND THE ADAPTER PLATE ONTO THE BELLHOUSING. PULL THE STARTER PINION SHAFT OUT TO ITS FULL TRAVEL LENGTH AND CHECK THAT THERE IS SUFFICIENT CLEARANCE.

PLACE THE ADAPTER PLATE ONTO THE ENGINE BLOCK. IF NECESSARY USE A RUBBER Mallet TO FIT THE PLATE UP TO THE BLOCK FLUSH. DO NOT USE THE CAP SCREWS TO FORCE THE PLATE ONTO THE BLOCK. IF THE PLATE WILL NOT SIT FLUSH TO THE BLOCK, CHECK THE DOWEL PINS ON THE BLOCK TO SEE IF THEY HAVE BEEN DAMAGED.

INSTALL THE CAP SCREWS AND THE SOCKET HEAD CAP SCREWS WITH THREAD LOCKING COMPOUND AND TORQUE IN A CRISS-CROSS PATTERN TO THE PROPER VALUES. AFTER TORQUING THE BOLTS, CHECK TO MAKE CERTAIN THAT NONE OF THE BOLTS PROTRUDE FROM THE SURFACE OF THE ADAPTER PLATE. IF NEEDED, TRIM THE BOLT HEADS OR SHANKS SO THAT THEY ARE FLUSH OR BELOW THE SURFACE OF THE ADAPTER PLATE. THE 2 7/16-14 BOLTS GO THROUGH THE BLOCK AND INTO THE ADAPTER PLATE FROM THE ENGINE SIDE. THE LONGER OF THE 2 GOES ON THE STARTER SIDE.

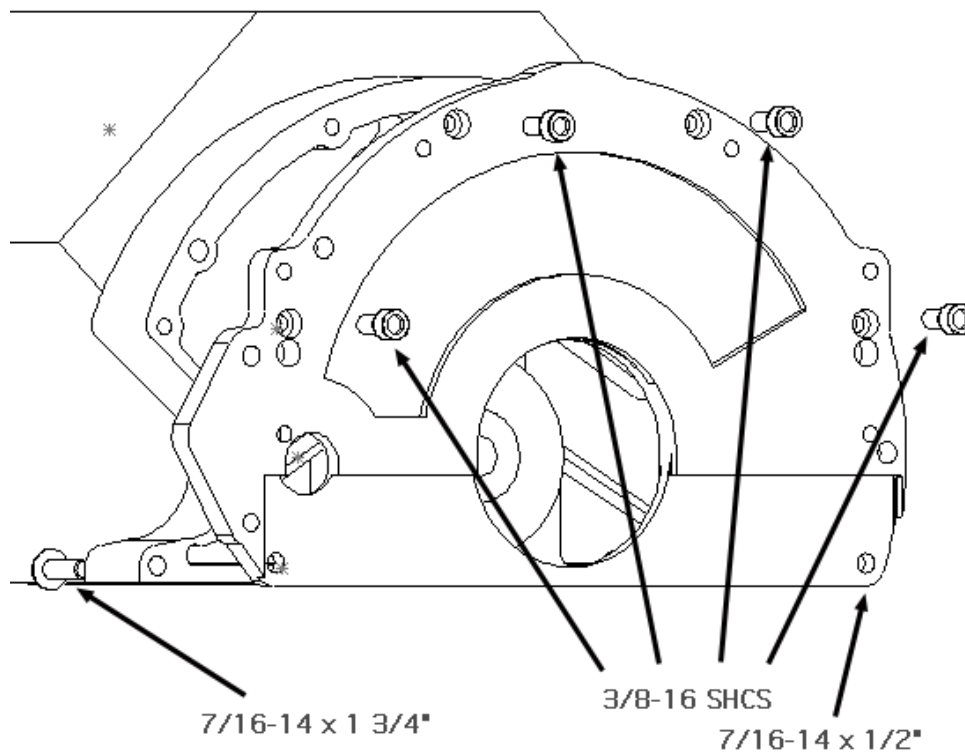

426-350 INSTALLATION INSTRUCTIONS

THE RING GEAR IS OFFSET TO THE ENGINE SIDE OF THE FLEX PLATE. FROM THIS SIDE, FIT THE HUB SPACER INTO THE FLEX PLATE AND ALIGN THE CRANKSHAFT BOLT HOLES. THE HUB SPACER SHOULD BE A CLOSE FIT TO THE CRANKSHAFT. INSTALL THE CRANKSHAFT BOLTS WITH THREAD LOCKING COMPOUND AND TORQUE TO THE PROPER VALUE. IMPORTANT! ANY TIME THAT ANY FORCE IS APPLIED TO THE HUB SPACER USE ONLY A RUBBER Mallet OR WOODEN DOWEL.

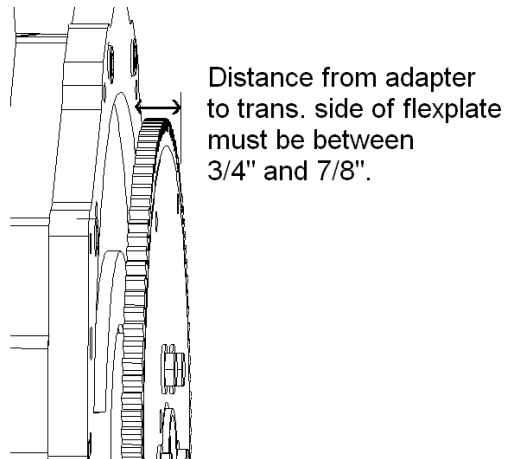

CHECK THE DISTANCE BETWEEN THE TRANSMISSION SIDE OF THE FLEXPLATE AND THE ADAPTER. THIS SHOULD BE BETWEEN .750" AND .875". **DO NOT PROCEED WITH THE INSTALLATION IF THIS IS NOT CORRECT.** ASSEMBLING THE MOTOR TO THE TRANSMISSION WITH THIS DIMENSION NOT IN TOLERANCE COULD RESULT IN TRANSMISSION OR STARTER DAMAGE. CONTACT WILCAP IF YOU FIND THIS DIMENSION TO BE GREATER THAN 7/8" OR LESS THAN 3/4".

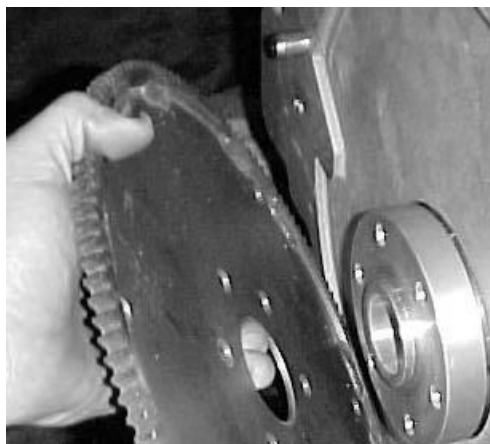

FIT UP THE STARTER MOTOR AND CHECK FOR PROPER RING GEAR TO PINION GEAR ENGAGEMENT. A SMALL AMOUNT OF MATERIAL MAY NEED

WILCAP COMPANY
P.O. Box 763 Pismo Beach, CA 93448
(805) 481-7639 Fax (805) 343-5000
www.wilcap.com

426-350 INSTALLATION INSTRUCTIONS

TO BE REMOVED FROM THE ENGINE BLOCK IN THE STARTER POCKET IN ORDER TO ALLOW THE STARTER TO SIT FLUSH TO THE ADAPTER PLATE. THE PINION GEAR NEED NOT ENGAGE THE RING GEAR FULLY 2/3-1/2 OF THE WIDTH OF THE RING GEAR IS SUFFICIENT. ADJUST THE TOOTH TO TOOTH ENGAGEMENT OF THE PINION GEAR TO RING GEAR IF NEEDED AND TORQUE STARTER BOLTS TO PROPER VALUE

BEFORE INSTALLING THE TRANSMISSION, CHECK THAT THE TORQUE CONVERTER IS FULLY SEATED INTO THE FRONT PUMP OF THE TRANSMISSION. THE TORQUE CONVERTER TO FLEXPLATE BOLT BOSSES SHOULD BE APPROXIMATELY 1" FROM THE BELLHOUSING FACE.

YOUR BELL HOUSING TO ADAPTER PLATE STUDS SHOULD GO INTO THE ADAPTER PLATE A MINIMUM OF 1/2". YOUR BELL HOUSING BOLTS SHOULD ALLOW FOR 1/2" OF THREAD INTO THE ADAPTER PLATE. ALSO CHECK THAT THE BOLTS DO NOT REACH PAST THE ADAPTER PLATE AND HIT THE BLOCK. USE THREAD LOCKING COMPOUND ON THE ADAPTER TO BELL HOUSING BOLTS.

BEFORE INSTALLING THE TRANSMISSION, CHECK THAT THE TORQUE CONVERTER IS FULLY SEATED INTO THE FRONT PUMP OF THE TRANSMISSION. THE TORQUE CONVERTER MATING BOSSES SHOULD BE APPROXIMATELY 1" FROM THE BELLHOUSING FACE.

WARNING!

Converter flex plate mounting bosses should be 1.0" from the flange when the converter is in fully engaged into the front pump drive.

Make certain this correct before installing the transmission. If the converter is not fully seated into the pump before installing the transmission, the front pump will be damaged!

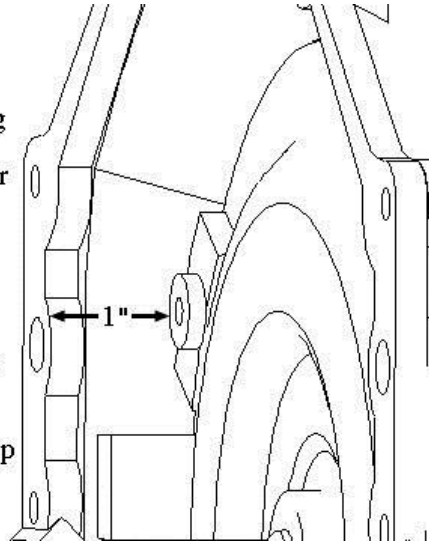

PLEASE NOTE; WHILE INSTALLING THE TRANSMISSION, REMEMBER THAT THE DOWEL PINS ARE FOR ALIGNMENT ONLY AND WILL NOT BEAR THE WEIGHT OF THE TRANSMISSION. CHECK THAT THE CONVERTER IS SEATED INTO THE FRONT PUMP PRIOR TO INSTALLING THE TRANSMISSION. CHECK THE "PULLBACK" DISTANCE OF THE CONVERTER PRIOR TO INSTALLING THE CONVERTER TO FLEX PLATE BOLTS.

426-350 INSTALLATION INSTRUCTIONS

YOUR WILCAP ADAPTER IS DESIGNED TO USE THE STOCK GM DUST COVER. DEPENDING ON THE ORIGINAL APPLICATION, THE DUST COVER MAY NEED TO BE MODIFIED SLIGHTLY. MAKE CERTAIN THAT THE COVER DOES NOT HIT THE RING GEAR, FLEXPLATE, OR CONVERTER. UNIVERSAL DUST COVERS ARE AVAILABLE FROM WILCAP.

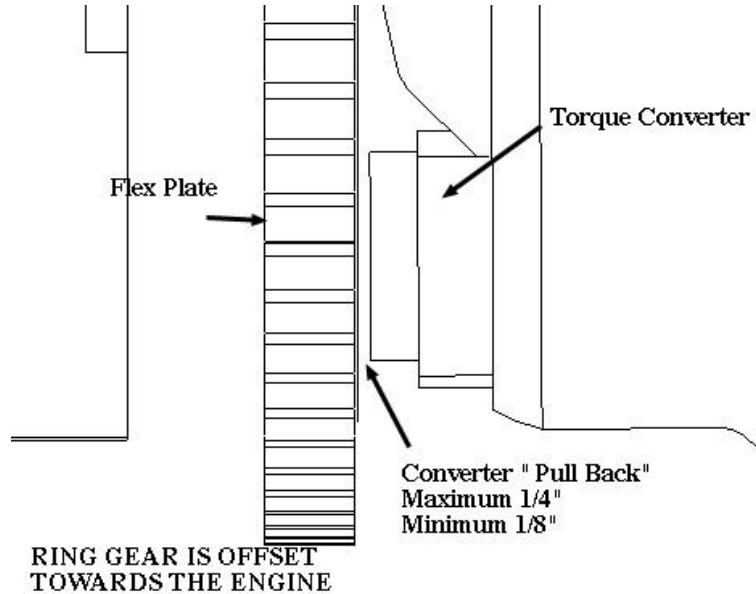

ALIGN THE CONVERTER AND THE FLEXPLATE HOLES AND START EACH BOLT. ROTATE THE ENGINE AS YOU TORQUE THE CONVERTER BOLTS TO THEIR FINAL VALUE IN AT LEAST THREE STEPS.

DO NOT HESITATE TO CONTACT US WITH ANY PROBLEMS, IDEAS OR SUGGESTION TO MAKE THIS PRODUCT BETTER. THANKS AGAIN FOR YOU BUSINESS.

WILCAP COMPANY
P.O. Box 763 Pismo Beach, CA 93448
(805) 481-7639 Fax (805) 343-5000
www.wilcap.com