

INSTRUCTION SHEET: P/N Cad-302 MT

IMPORTANT: THIS IS A HIGH PERFORMANCE PART AND IMPROPER INSTALLATION COULD RESULT IN INJURY OR DEATH! NEVER WORK UNDER AN AUTOMOBILE THAT IS NOT PROPERLY SUPPORTED AND BLOCKED FROM ROLLING. ALWAYS INSTALL NEUTRAL SAFETY SWITCH. FAILURE TO DO SO CAN RESULT IN INJURY OR DEATH!

NO CREDIT OR REFUND WILL BE ISSUED FOR PARTS DAMAGED DUE TO IMPROPER INSTALLATION OR MISAPPLICATION. REMEMBER THAT YOUR ADAPTER PLATE IS ALUMINUM AND NOT CAST IRON. DO NOT OVERTORQUE THE FASTENERS. IF AT ANYTIME YOU HAVE ANY QUESTIONS ABOUT THIS INSTALLATION, CONTACT WILCAP IMMEDIATELY. THE INSTALLATION AND USE OF THIS PRODUCT IS DONE AT YOUR OWN RISK

YOUR WILCAP ADAPTER IS DESIGNED TO USE THE MOPAR SMALL BLOCKGEAR REDUCTION "MINI" STARTER OR ANY EQUIVALENT MOPAR STARTER. THESE STARTERS ARE AVAILABLE FROM WILCAP OR YOUR LOCAL PARTS HOUSE SHOULD BE ABLE TO SUPPLY ONE USING THE FOLLOWING PART NUMBERS;

CHRYSLER P/N 53005984

NIPPONDENSO P/N 128000-781 OR 128000-7810

MOPAR PERFORMANCE P/N/ P5249644

POWERMASTER P/N 9300, 9512, OR 9613

TILTON P/N 54-10000

AUTOLITE PRO P/N 17466

BECK ARNLEY P/N 187-0436

TYPICAL APPLICATION OF THE STARTER WOULD BE A 1992 DODGE DAKOTA WITH THE 5.2L ENGINE.

YOUR WILCAP FLYWHEEL IS STATICALLY BALANCE ONLY! YOUR FLYWHEEL SHOULD BE DYNAMICALLY BALANCED ALONG WITH THE OTHER ROTATING PARTS OF YOUR ENGINE TO INSURE SAFE OPERATION.

INSTRUCTION SHEET: P/N Cad-302 MT

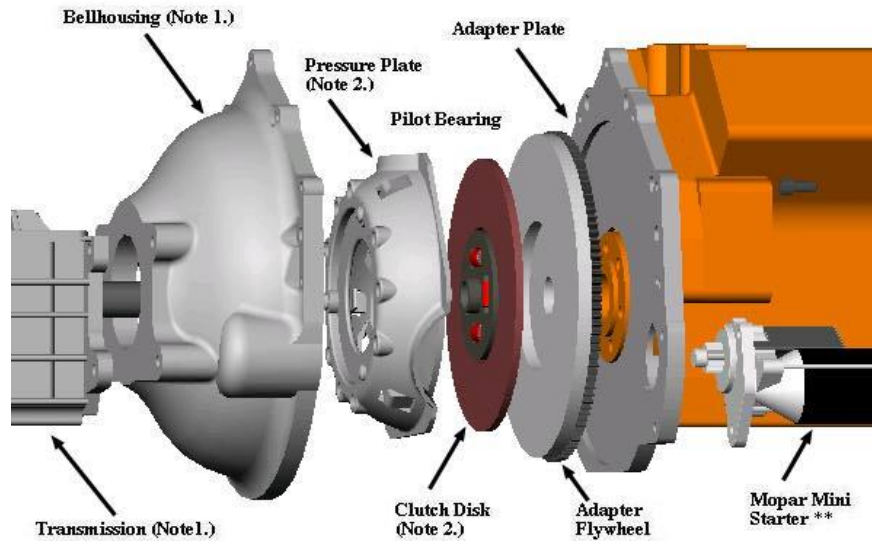

NOTE 1. USE THE FORD SB BELLHOUSING, THROWOUT BEARING AND LINKAGE (FORK) THAT WERE STOCK TO YOUR TRANSMISSION

NOTE 2. THE FLYWHEEL IS DRILLED FOR THE 10.5" GM PRESSURE PLATE AND THE 10" FORD PRESSURE PLATE. IF YOU NEED ASSISTANCE IN SELECTING THE CORRECT CLUTCH/PRESSURE PLATE, CONTACT WILCAP.

CHECK THAT ALL OF THE FOLLOWING PARTS ARE IN THE PACKAGE AND FREE OF DAMAGE;

- 1 ALUMINUM ADAPTER PLATE
- OFFSET BOLT
- FLYWHEEL
- PILOT BEARING ADAPTER
- FASTENERS;

- 1- 3/8-16 X 1 1/2" UNC CAP SCREWS
- 1 - 3/8 -16 X 1 3/4" UNC CAP SCREW
- 6 – 3/8 STUDS, LOCK WASHERS, & NUTS
- 2 – 7/16 X 1 ¼ UNC CAP SCREWS
- 3 - 7/16-14 X 1" UNC SOCKET HEAD CAP SCREWS
- 1 – 7/16-14 x 1" UNC SOCKET HEAD C.S. WITH TURNED DOWN HEAD
- 6 – 7/16-20 UNF GRADE 8 FLYWHEEL BOLTS AND WASHERS

TORQUE VALUES: CONTINUED ON NEXT PAGE

Wilcap Company
P.O. Box 763
Pismo Beach, CA 93448
(805) 481-7639
www.wilcap.com
Copyright 2004 All Rights Reserved.

INSTRUCTION SHEET: P/N Cad-302 MT

ADAPTER PLATE TO ENGINE	7/16-14 SHCS 40-45 FTLBS 3/8-16 HEX HEAD BOLTS 35-40 FTLBS
CRANK SHAFT BOLTS	75-80 FTLBS
BELLOUSING NUTS	30-40 FTLBS

YOUR WILCAP ADAPTER IS DESIGNED TO USE THE OEM THROWOUT BEARING AND LINKAGE THAT WAS STOCK FOR YOUR TRANSMISSION. IF YOU USE A NON-STOCK BEARING OR LINKAGE, MAKE CERTAIN THAT THE THROWOUT BEARING ENGAGES THE FINGERS OF YOUR PRESSURE PLATE CORRECTLY BEFORE PROCEEDING.

CLEAN THE CRANKSHAFT FLANGE AND HUB USING SOLVENT AND A RAG AND INSPECT FOR BURRS, DINGS, NICKS, ETC. THIS IS CRITICAL! THE ALIGNMENT OF THE ENTIRE ROTATING ASSEMBLY RELIES ON THE FACE OF THE CRANKSHAFT AND THE HUB SPACER MATING EXACTLY. REMOVE ANY BURRS WITH A FINE PITCH FILE.

CLEAN AND INSPECT THE BLOCK MOUNTING SURFACE AND THE TRANSMISSION MOUNTING SURFACE AND REMOVE ANY BURRS. CHASE AND CLEAN ALL OF THE BLOCK TO BELL HOUSING BOLT HOLES AND REPAIR ANY DAMAGED THREADS.

DRILL THE 2 LOWEST BELL HOUSING BOLT HOLES ON THE BLOCK USING A 3/8" DRILL BIT. THIS WILL ALLOW FOR THE USE OF THE 2 3/8-16 CAP SCREWS TO FASTEN INTO THE ADAPTER PLATE FROM THE ENGINE SIDE.



PLACE THE ADAPTER PLATE ONTO THE ENGINE BLOCK. IF NECESSARY USE A RUBBER Mallet TO FIT THE PLATE UP TO THE BLOCK FLUSH. DO

Wilcap Company
P.O. Box 763
Pismo Beach, CA 93448
(805) 481-7639
www.wilcap.com
Copyright 2004 All Rights Reserved.

INSTRUCTION SHEET: P/N Cad-302 MT

NOT USE THE CAP SCREWS TO FORCE THE PLATE ONTO THE BLOCK. IF THE PLATE WILL NOT SIT FLUSH TO THE BLOCK, CHECK THE DOWEL PINS ON THE BLOCK. IF THEY PROTRUDE MORE THAN 3/8" OR HAVE BEEN DAMAGED AND THE ADAPTER PLATE IS FORCED ONTO THE BLOCK, THE ADAPTER PLATE WILL BE DAMAGED!

ONCE THE ADAPTER PLATE IS FLUSH, MARK THE PLATE FOR ANY TRIMMING OR CUTTING FOR CLEARANCE. IF THE PLATE WILL BE TRIMMED, BE CAREFUL NOT TO CUT TOO CLOSE TO ANY OF THE FASTENER HOLES AND REMOVE ANY BURRS LEFT FROM CUTTING.

AFTER ANY CUTTING OR TRIMMING HAS BEEN COMPLETED, INSTALL THE CAP SCREWS AND THE SOCKET HEAD CAP SCREWS WITH THREAD LOCKING COMPOUND AND TORQUE IN A CRISS-CROSS PATTERN TO THE PROPER VALUES. AFTER TORQUING THE BOLTS, CHECK TO MAKE CERTAIN THAT NONE OF THE BOLTS PROTRUDE FROM THE SURFACE OF THE ADAPTER PLATE. IF NEEDED, TRIM THE BOLT HEADS OR SHANKS SO THAT THEY ARE FLUSH OR BELOW THE SURFACE OF THE ADAPTER PLATE. THE SINGLE 1 3/4" 3/8-16 BOLT IS FOR THE DRIVERS SIDE, ENGINE SIDE HOLE.

INSTALL THE PILOT BEARING INTO THE BACK OF THE CRANKSHAFT. FIRST CAREFULLY CLEAN THE REAR OF THE CRANK SHAFT PILOT BORE. SOME ENGINES HAD A FLAT SPACER THAT IN THE BOTOM OF THE CRANK BORE THAT CAN BE REMOVED WITH A MAGNET. THE PILOT BEARING SHOULD BE A TIGHT PRESS FIT INTO THE CRANK AND WILL REQUIRE FORCE TO PRESS INTO THE CRANK. A PLASTIC RUBBER Mallet OR A BLOCK OF WOOD SHOULD BE USED . MAKE CERTAIN THE PILOT BEARING IS FLUSH OR SLIGHTLY BELOW THE BACK OF THE CRANK BOSS.

CAREFULLY ALIGN THE FLYWHEEL AND THE CRANKSHAFT BOLT HOLES WHILE PLACING THE FLYWHEEL ONTO THE CRANKSHAFT. THE FLYWHEEL SHOULD BE A CLOSE FIT TO THE CRANKSHAFT. INSTALL THE CRANKSHAFT BOLTS WITH THREAD LOCKING COMPOUND AND TORQUE TO THE PROPER VALUE.

FIT UP THE STARTER MOTOR AND CHECK FOR PROPER RING GEAR TO PINION GEAR ENGAGEMENT. ADJUST IF NEEDED AND TORQUE STARTER BOLTS TO PROPER VALUE

WHILE INSTALLING THE TRANSMISSION, REMEMBER THAT THE DOWEL PINS ARE FOR ALIGNMENT ONLY AND WILL NOT BEAR THE WEIGHT OF

INSTRUCTION SHEET: P/N Cad-302 MT

THE TRANSMISSION. IF THE ENTIRE WEIGHT OF THE TRANSMISSION IS PUT ONTO THE DOWELS THEY WILL BE PULLED FROM THE ADAPTER PLATE.

THE BELL HOUSING TO ADAPTER PLATE STUDS SHOULD GO INTO THE ADAPTER PLATE A MINIMUM OF 1/2". ALSO CHECK THAT THE BOLTS DO NOT REACH PAST THE ADAPTER PLATE AND HIT THE BLOCK. USE THREAD LOCKING COMPOUND ON THE ADAPTER TO BELL HOUSING BOLTS.

ONCE THE ADAPTER PLATE IS FLUSH, ROTATE THE OFFSET FASTENERS TO LINE UP THE MARKS ON THE PLATE WITH THOSE ON THE FASTENER.



ONCE THE TRANSMISSION BELL HOUSING IS IN PLACE, CHECK FOR CLEARANCE OF THE STARTER PINION GEAR AND SHAFT TO TRANSMISSION BELL HOUSING AND REMOVE MATERIAL FROM THE INSIDE OF THE BELL HOUSING IF NEEDED.

DO NOT HESITATE TO CONTACT US WITH ANY PROBLEMS, IDEAS OR SUGGESTION TO MAKE THIS PRODUCT BETTER. THANKS AGAIN FOR YOU BUSINESS.