

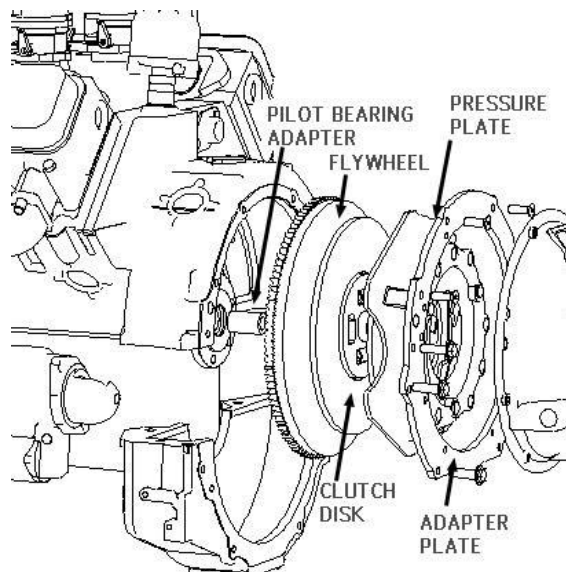

303-EFM Olds/Cadillac to Early Ford ENGINE TO TRANSMISSION ADAPTER

ENGINE APPLICATION YEARS/CID:	V8 CADILLAC 331 CI 1949-53, V8 OLDSMOBILE 303,324, 371, 394 CI 1949-64
TRANS APPLICATION YEAR/MODEL:	FORD 1932-1948, MERC 1939-1950, FORD TRUCK 1/2 TO 1 1/2 TON 1949-1953
STARTER USED:	STOCK ENGINE STARTER MATCHED TO F.W
FLYWHEEL USED:	STOCK FLYWHEEL SEE NOTES
CLUTCH USED:	B&B COVER, (SEE NOTES) FORD CLUTCH DISK
MATERIAL / MACHINING METHODS:	WILCAP CNC MACHINED BLANCHARD GROUND STEEL PLATE, DOWEL PINS, ALLOY ENGINE TO ADAPTER FASTENERS. WILCAP PILOT BEARING ADAPTER.
ADDITIONAL PARTS NEEDED:	ENGINE, TRANSMISSION, STOCK ENGINE FLYWHEEL, STARTER, & CLUTCH COVER. FORD THROW OUT BEARING AND FORD CLUTCH DISK.



NOTES; We can supply the throw out bearing with hardware and the correct clutch cover and disk. Wilcap can also fabricate a new steel or aluminum flywheel for your project or recondition your stock flywheel. Complete instructions are included. We do not supply information regarding engine or transmission installation in to specific frames, bodies, etc. This is the responsibility of the customer and care should be taken to address the issues of motor and transmission mounts, driveline, body and frame clearance, gear ratios, etc. BEFORE the purchase of the engine to transmission adapter. We can assist you with information and dimensions prior to the start of your project so feel free to contact us with any questions.

WILCAP COMPANY
P.O. BOX 763, PISMO BEACH, CA 93448
(805) 481-7639 FAX (805) 481-9367

www.wilcap.com

Copyright 2008 All rights reserved.