

350-292 ADAPTER INSTALLATION INSTRUCTIONS

IMPORTANT: THIS IS A HIGH PERFORMANCE PART AND IMPROPER INSTALLATION COULD RESULT IN INJURY OR DEATH! NEVER WORK UNDER AN AUTOMOBILE THAT IS NOT PROPERLY SUPPORTED AND BLOCKED FROM ROLLING. NO CREDIT OR REFUND WILL BE ISSUED FOR PARTS DAMAGED DUE TO IMPROPER INSTALLATION. REMEMBER THAT YOUR ADAPTER PLATE IS ALUMINUM AND NOT CAST IRON. DO NOT OVERTORQUE THE FASTENERS. IF AT ANYTIME YOU HAVE ANY QUESTIONS ABOUT THIS INSTALLATION, CONTACT WILCAP IMMEDIATELY. THE INSTALLATION AND USE OF THIS PRODUCT IS DONE AT YOUR OWN RISK.

CLUTCH DISKS SHOULD NEVER BE HANDLED WITH DIRTY HANDS. CONTAMINATION OF THE FRICTION SURFACE WITH OIL OR GREASE WILL SHORTEN THE LIFE OF THE CLUTCH. PRIOR TO ASSEMBLY ALL CLUTCH COMPONENTS SHOULD BE CLEANED THOROUGHLY.

THE ADAPTER IS DESIGNED TO USE THE STOCK FLYWHEEL, STARTER, PRESSURE PLATE, AND BELLHOUSING FROM YOUR ENGINE. THE CLUTCH DISK USED IS THE CORRESPONDING DISK MATCHING THE TRANSMISSION INPUT SHAFT AND THE PRESSURE PLATE DIAMETER. FOR EXAMPLE; IF YOUR STOCK PRESSURE PLATE FOR YOUR ENGINE IS 11", YOU WILL NEED AN 11" CLUTCH DISK WITH THE TRANSMISSIONS INPUT SHAFT SPLINE

THE FORD BEARING CAN BE TURNED DOWN ON A LATHE THE FORD DIAMETER (1.370") OR THE FORD BEARING CAN BE MODIFIED TO WORK WITH THE CHEVROLET THROW OUT BEARING ARM. WE RECOMEND THAT THE BEARING RETAINER BE TURNED DOWN OR THAT YOU USE A HYDRAULIC THROW OUT BEARING. IN ADDITION, THE LENGTH OF THE T5 BEARING RETAINER MAY NEED TO BE SHORTENED DEPENDING ON YOUR TRANSMISSION MODEL. SEE THE NOTES BELOW.

UNPACK AND CHECK FOR SHIPPING DAMAGE PRIOR TO BEGINNING THE INSTALLATION. PACKAGE SHOULD INCLUDE;

- 1 ALUMINUM ADAPTER PLATE
- 1 PILOT BEARING ADAPTER

FASTENERS;

- 2 1/2-13X 1 1/2" FLATHEAD SOCKET HEAD CAP SCREWS
- 2 1/2-13X 1 1/2" GRADE 8 HEX BOLTS AND LOCK WASHERS
- 4 7/16-14 X 1 1/2" GRADE 8 HEX BOLTS AND LOCK WASHERS

350-292 ADAPTER INSTALLATION INSTRUCTIONS

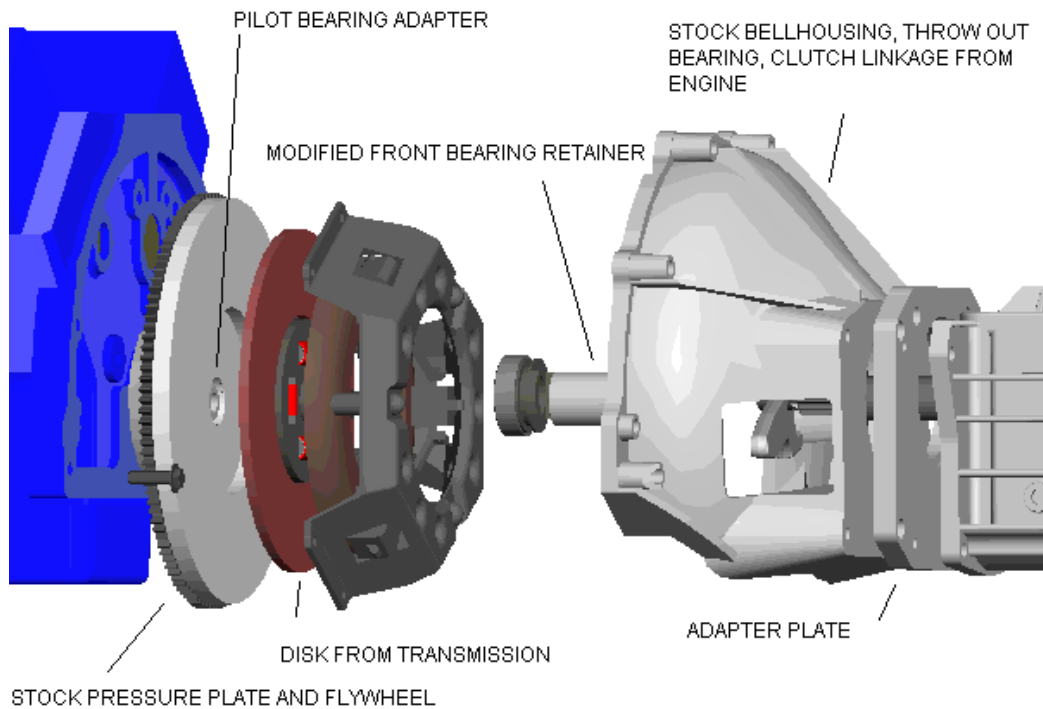

PLACE THE ADAPTER PLATE ONTO THE BELLHOUSING. IF NECESSARY USE A RUBBER Mallet TO FIT THE PLATE UP FLUSH. INSTALL THE SOCKET HEAD CAP SCREWS USING A THREAD LOCKING COMPOUND AND TORQUE. DO NOT USE THE CAP SCREWS TO FORCE THE PLATE ONTO THE BELLHOUSING. MAKE CERTAIN THE ADAPTER PLATE SITS FLUSH TO THE BACK OF THE BELLHOUSING AND THERE IS NO GAP.

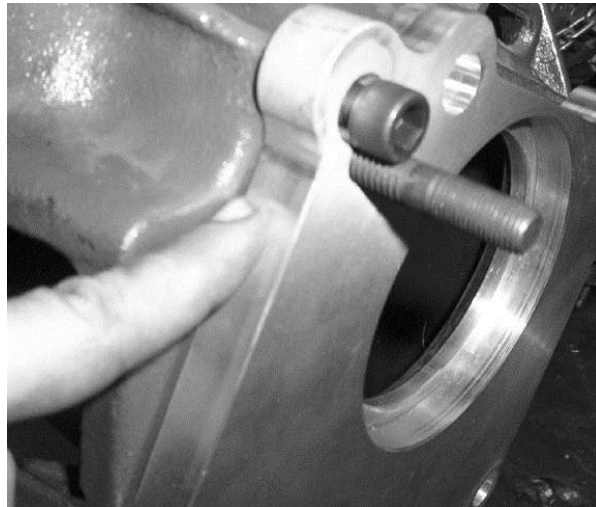

INSTALL THE TRANSMISSION TO ADAPTER PLATE BOLTS USING A THREAD LOCKING COMPOUND ONLY AFTER THE PLATE IS BOLTED INTO PLACE ON THE BELLHOUSING..

350-292 ADAPTER INSTALLATION INSTRUCTIONS

THE BEST METHOD TO INSURE PILOT BEARING ENGAGEMENT IS TO INSTALL THE TRANSMISSION WITHOUT THE FLYWHEEL IN PLACE. VIEWING THROUGH THE THROW OUT BEARING ARM WINDOW, MAKE CERTAIN THAT THE TRANSMISSION PILOT ENTERS THE BEARING A MINIMUM OF 3/8". IF THE TRANSMISSION DOES NOT ENGAGE THE PILOT BEARING, CONTACT WILCAP FOR AN ADAPTER PILOT BEARING. SOME CRANKS ARE DRILLED SHALLOWER THAN OTHERS. MAKE CERTAIN THAT THE INPUT SHAFT DOESN'T BOTTOM IN THE BORE OF THE CRANKSHAFT. IF THIS IS THE CASE, THE INPUT SHAFT PILOT WILL HAVE TO BE CUT DOWN. THIS CAN BE DONE WITH AN ABRASIVE CUT-OFF SAW. BE SURE TO GRIND A SMALL CHAMFER ON TO THE END OF THE PILOT SHAFT IF THIS OPERATION IS NEEDED.

MEASURE THE DISTANCE OF THE BEARING RETAINER FROM THE CRANKSHAFT FLANGE. THIS SHOULD BE A MINIMUM OF 2 1/4". IF IT IS LESS THEN THE BEARING RETAINER WILL NEED TO BE SHORTENED

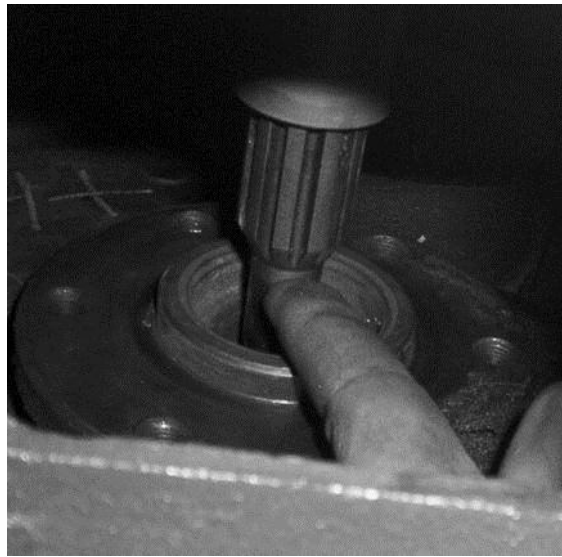

INSTALL THE FLYWHEEL, CLUTCH DISK AND PRESSURE PLATE. TORQUE DOWN THE ALL BOLTS IN A CRISS-CROSS PATTERN.

INSTALL THE THROW OUT BEARING FORK, THROW OUT BEARING AND CARRIER (WITH SLEEVE IF NEEDED), BELLHOUSING AND TRANSMISSION.

CHECK THE THROW OUT BEARING TO CLUTCH FINGER GAP. THIS SHOULD BE WITHIN THE ENGINES STOCK SPECIFICATIONS.

DO NOT HESITATE TO CONTACT US WITH ANY PROBLEMS, IDEAS OR SUGGESTION TO MAKE THIS PRODUCT BETTER. THANKS AGAIN FOR YOUR BUSINESS.

350-292 ADAPTER INSTALLATION INSTRUCTIONS